

Whisper – Wall Fan Heater

The Whisper Wall Fan Heater is a metal bodied heater ideal for bathrooms, kitchens and areas requiring localised, controllable heat. The Whisper features a variable thermostat, with a frost protection setting, for increased economy, pullcord operation, automatic overheat safety cut-out and a power-on indicator light. For ease of installation it is fitted with a 0.9m cable.

Features:

Thermostatic control • Pull-cord operation • Automatic safety cut-out • Power-on indicator Fitted power supply cable • Fixing/Securing bracket • Finished in Crisp White or stainless • 190(h) x 115(d) x 300(w) mm

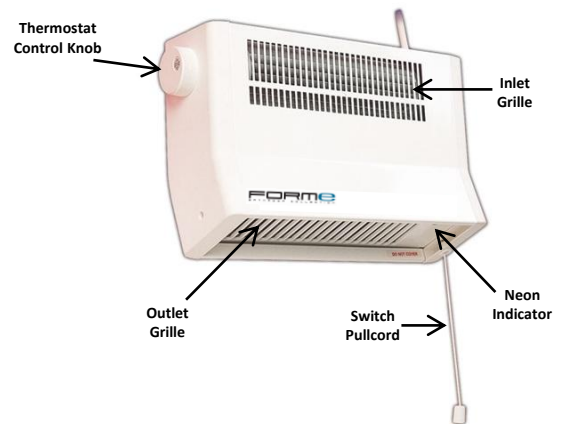

Installation

Ensure that the electricity supply is disconnected from any relevant fixed wiring before commencing the installation. Ensure that the mains supply voltage is as stated on the rating label. The supply circuit must be adequate for the input of the appliance. **This unit must be installed by a registered electrician.** The installation of this product must comply with NZS 3000.2007.

- The appliance should be fitted horizontally such that the cable entry is uppermost and the pullcord is at the bottom.
- The unit must be mounted a minimum of 1.8m from the floor, also a minimum of 150mm below ceiling level or any other projecting surface. It must also not be less than 250mm from any adjacent projecting surface.
- The unit must not be located immediately below a fixed socket outlet.
- Ensure that when in use the airstream is not obstructed by a cupboard or similar object.
- Do not attempt to repair the heater or unscrew the outer casing yourself.
- Do not place aerosols or similar containers or materials susceptible to heat in the direct airstream.

Mounting Procedure

- Using the mounting bracket supplied as a template, position it horizontally at a minimum of 1.92m from the floor to the underside of the bracket and mark the position of the three fixing holes (Ref A in diagram)
- Drill and plug the wall suitable of No. 8 screws
- Insert the two keyhole screws in the wall leaving approximately 2mm gap between head and wall.
- Secure the mounting bracket to the appliance using the three No. 6 screws supplied (Ref B in diagram)
- Position the appliance on the partially inserted wall screws and secure the third wall screw immediately above the appliance.

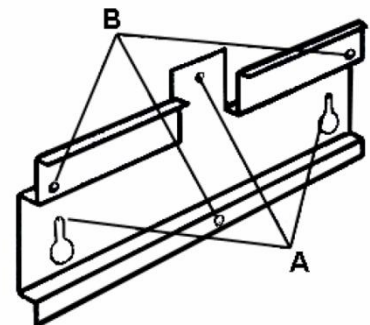

Controls

The Whisper has a heat loading of 2kW. The heater is controlled by a pullcord operated on/off switch. A neon indicator when lit shows that the unit is operational.

The appliance is fitted with an Electronic Safety Control (ES). This is a safety device which switches off the heater if for any reason the appliance overheats. The ES control can only be re-set after the appliance has cooled down. In order to re-set the ES Control proceed as follows:

- Switch off appliance by means of pullcord and leave for approximately 5 mins
- Switch appliance back on and ES control will re-set
- Ensure that the appliance is functioning correctly. If the ES Control operates again, the appliance should be checked by a registered electrician.

CAUTION: In order to avoid a hazard due to inadvertent resetting of the thermal cut-out, this appliance must not be supplied through an external switching device, such as a timer, or connected to a circuit that is regularly switched on and off by the utility.

Thermostat Control

The Whisper is fitted with a thermostat.

To set the thermostat to the required temperature, turn the control knob fully clockwise. When the desired room temperature is reached, turn the knob slowly anti-clockwise and when the thermostat 'clicks' off, leave the control at this setting. Thereafter, the fan heater will control the heat output automatically.

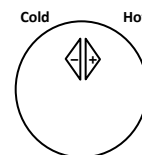

To set the heater to the Frost Watch mode, rotate the thermostat control knob fully to the lowest setting (N, 1). Thereafter the heater will trip in if the temperature drops sufficiently. The heater needs to be in the "ON" mode with the neon indicator light illuminated for this function to operate.

Safety

- This heater has been designed and manufactured to the highest international standard, but, like all other electrical appliances which are operated by mains voltage, care must be taken if you are to obtain the best results and safety is to be assured.
- This appliance is not intended for use by persons (including children) with reduced physical, sensory or mental capabilities, or lack of experience and knowledge, unless they have been given supervision or instructions concerning use of the appliance by a person responsible for their safety.
- Children should be supervised to ensure that they do not play with the appliance.
- The heater is to be installed so that switches and other controls cannot be touched by a person in the bath or shower.
- The heater must not be installed in front of a socket-outlet.
- Means for disconnection must be incorporated in the fixed wiring in accordance with the wiring rules.
- If the supply cord is damaged, it must be replaced by the manufacturer, its service agent or similarly qualified persons in order to avoid a hazard.
- Do not handle the appliance with wet hands.
- Do not use the appliance in workshops or rooms where excessive dust is generated or present.
- Ensure that nothing is pushed into any aperture of this appliance.
- Do not touch the outlet grill when the appliance is in use.

Cleaning

Always disconnect the heater from the mains before cleaning. The fan heater should always be kept clean. An occasional wipe over with a soft cloth is all that should be necessary, ensuring all inlet and outlet vents are kept dust free.

- Do not use metal or furniture polish on any part of the heater.
- Do not touch the heater with wet hands or in any way bring water in contact with it.

The supply cord on this appliance can only be replaced by the use of special tools, and should any damage or fault occur to the heater, it must be serviced by an accredited service agent.

Product Warranty – 2 year in-home warranty

Any bathroom heater that is found to be defective due to substandard materials and/or workmanship within **2 (two)** years from the date of purchase, will be replaced. To make a claim under this warranty, contact Tranquillity New Zealand on 0800 805 558.

Your warranty applies only if:

- Your heater is installed, tested and signed off by a registered electrician.
- You provide us with written proof of your purchase and your warranty registration.

If this warranty applies:

- Tranquillity New Zealand will send out a qualified person to repair/replace the heater on site.
- Repair or replacement of the heater will be at Tranquillity's discretion.

The benefits given by this warranty are additional to other rights and remedies that you may have under laws relating to our products. Our goods come with guarantees that cannot be excluded under the New Zealand/Australian Consumer Law. You are entitled to a replacement or refund for a major failure and for compensation for any other reasonably foreseeable loss or damage. You are also entitled to have the goods repaired or replaced if the goods fail to be of acceptable quality and the failure does not amount to a major failure. If you have any questions about the performance of your heater, which may not be to your satisfaction, please call Tranquillity New Zealand - Freephone: 0800 805 558.

Tranquillity New Zealand is not responsible for:

- Damage done or repairs required as a consequence of the faulty installation or application of your heater.
- Damage done as a result of environmental factors affecting your heater which are beyond Tranquillity's control.
- Damage done or repairs required as a result of any improper use, maintenance, operation or servicing of your heater.
- Incidental on consequential damage of any kind, including but not limited to costs or expenses resulting from damage to any property.